

Fabric or Leather should not exceed the height!

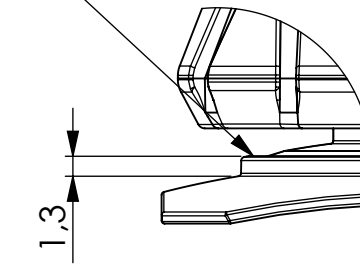

FIDLOCK®

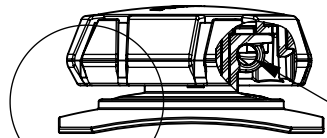
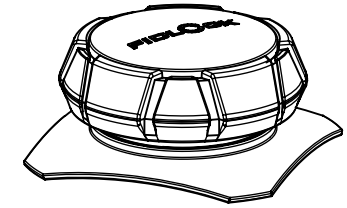

TRUE R1,38

A

DETAIL A

MABSTAB 2 : 1

product	WINCH
opening	Pull
material	PA6, PA6 GF15, NbFeB, Epoxy
colour	black
lace/string diameter	1,2 - 2,75 mm
lace/string max. capacity	500 mm
lace/string attachment	overhand knot, figure eight knot
weight	9,7 g
load capacity	200 N
washability	max. 60 degree
general notes	stitchable base, delivery without Lace/String, String braided, polyester fibers, nylon;

Ø 24,49

sewing and glueing surface

Proceed like stitching zipper
Use a zipper presser foot and
stitch length 2-3 mm
(For securing the thread we
recommend choosing a position
next to the Fidlock part. Otherwise
stability could be reduced.)

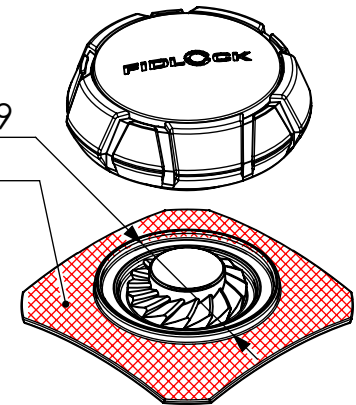

Article No	01500
Scale	1:1
Date	14.04.2021
Author	SO

patented technology.